

## BIS1.5A Fiber Coupled Integrating Sphere



The BIS1.5 is a compact fiber coupled integration sphere. It is highly reflective (99% from 400nm-800nm) and Lambertian over the broad spectral range of 250nm-2500nm machined from PTFE.

### Applications:

- Optical Power Measurement
- Diffused Transmittance Measurement
- LD Measurement
- LED Measurement

### Features:

- High Reflectivity > 97% over most of 250nm-2500nm
- Compact Size
- Fiber Coupled
- Custom Configurations Available

### Dimensions:

Units: in

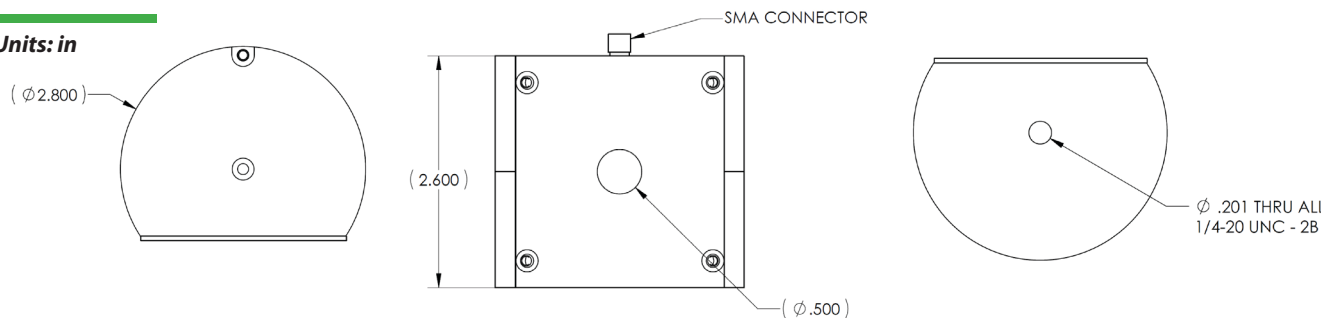

### PTFE Reflectivity:

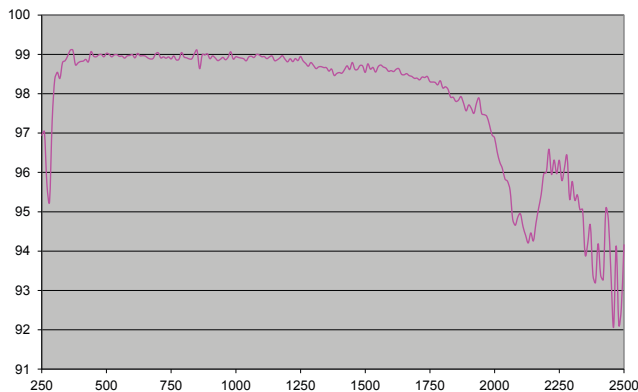

### Experiment Setup:

