

FRC100 Fiber Optic Near Cosine Corrector

Spectrometer Accessory

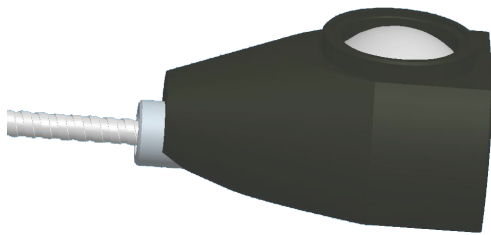

The FRC100 is a right angle transmissive near cosine corrector for measuring spectral irradiance. Featuring a diffuser made from PTFE, the FRC100 can be used from the UV to the NIR range. When compared to integrating spheres, the FRC100 provides greater optical efficiency and improved signal sensitivity over a broad spectral range. A 600µm Fiber Patch Cord with metal sheathing is provided which connects to the SMA 905 connector on the FRC100 and to a spectrometer on the other end. A working setup would consist of an FRC100, a Spectrometer, and Irradiance Calibration.

Features:

- 220 – 2500nm spectral transmission
- SMA 905 fiber connector
- Low profile, convenient 90° viewing
- Can be calibrated for spectral irradiance

Applications:

- Spectroradiometry
- Color measurement
- Illumination and color rendering from lighting
- Solar irradiance monitoring (outdoors)
- Solar simulator validation (indoors)
- UV curing system QC
- Suitable input optic for LED and lamp characterizations

Dimensions:

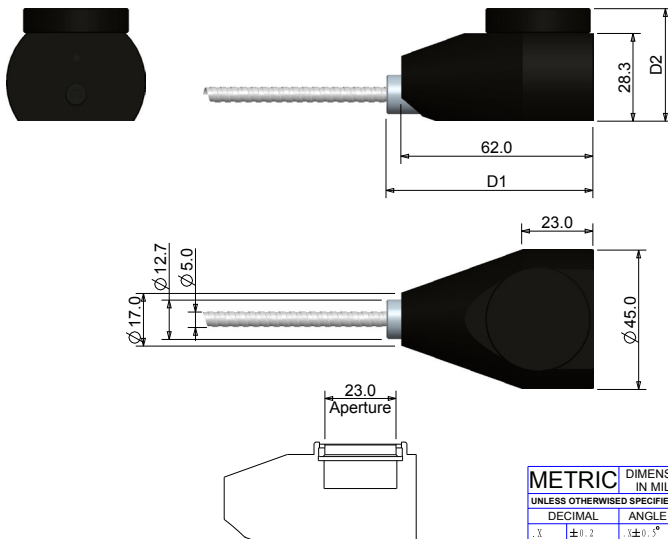

METRIC		DIMENSIONS ARE IN MILLIMETER	
UNLESS OTHERWISE SPECIFIED TOLERANCES			
DECIMAL	ANGLE	SURFACE	
.X	±0.2	.X±0.5°	1.6
.XX	±0.05	.XX±0.05°	
.XXX	±0.005		
.XXXX	±0.0005		

NOTE:
 Operating temperature of 0-70° C
 Relative humidity of 0-85% RH non condensing
 Length of the fiber cable is 1.5m
 D1: 66-72mm, D2: 36-38mm

