

# High Throughput Raman Probe



Innovative Photonic Solutions (IPS) is proud to introduce our Raman probe optimized to mate with IPS' multimode fiber coupled lasers to offer higher throughput and lower stray light. This probe has been designed to optimize collection efficiency for both single- and dual-wavelength laser sources which are utilized to capture both the fingerprint and stretch-bands of the Raman spectrum with a single spectrometer. The probe has a flexible design that allows IPS to optimize collection efficiency for low or high f# spectrometers, and customers can select the excitation wavelength, Raman cut-on wavenumber, sample working distance, and excitation & collection fiber type.

## Applications

This laser package is designed for OEM Integration and is ideal for:

- High Resolution Raman Spectroscopy
  - Portable Raman
  - Process Raman

## Key Features

- High Throughput
- Compact Design
- Removable Fibers
- Configurable Probe tips for both laboratory and immersion applications
- Embedded Teflon standard in shutter for reference measurement.
- Configurable working distance (1.6mm to 20mm).
- Configurable excitation optics of optimizing NA (0.18-0.55) for different excitation fibers.
- Configurable collection optics of optimizing NA (0.18-0.55) for different f# spectrometers.

## Standard Wavelengths

532nm	785nm	860/1064nm
638nm	808nm	976nm
680nm	830nm	1064 nm
680/785nm		

# Specifications



Parameter	Unit
Excitation Fiber	Typically 105 micron, 0.22 NA step index multimode fiber with FC/PC termination. Other fibers available upon request.
Collection Fiber	1.5 m long 200-400 micron, 0.37 multimode with SMA termination (Other fibers available upon request)
Cut-on	65 cm <sup>-1</sup> , 125 cm <sup>-1</sup> or 200 cm <sup>-1</sup>
Shaft Material	316L Stainless Steel Standard
Fiber Bend Radius	2 Inches
Working Distances	8.1 mm & 9.7mm working distance standard (+/- 0.5mm) - Custom distances available upon request.
Operating Temperature	0 °C to + 50 °C
Storage Temperature	-20 °C to 80 °C
Humidity	0-80% non-condensing

## Raman Concatenation

Issues with strong fluorescence limit the use of Raman spectroscopy techniques and often force the use of longer excitation wavelengths to minimize the fluorescence background. The use of longer excitation wavelengths shifts the stretch band of the Raman spectra into low efficiency regions of the detection system and therefore forces the use of expensive deep cooled cameras and/or the sacrifice of long wavenumber spectral information. Raman concatenation is a technique that offers the ability to use longer excitation wavelengths and still collect the entire Raman spectrum without the need for expensive detection systems and/or long integration times, and at no increase in noise. Raman spectra are captured separately from each of the two excitation wavelengths and subsequently concatenated, or stitched together, to provide a single spectral scan encompassing the entire range of data, including the fingerprint and stretch regions. Furthermore, this technique offers both increased selectivity and enhanced discrimination between spectral features in the long wavenumber region of the spectra.

## Part Schema

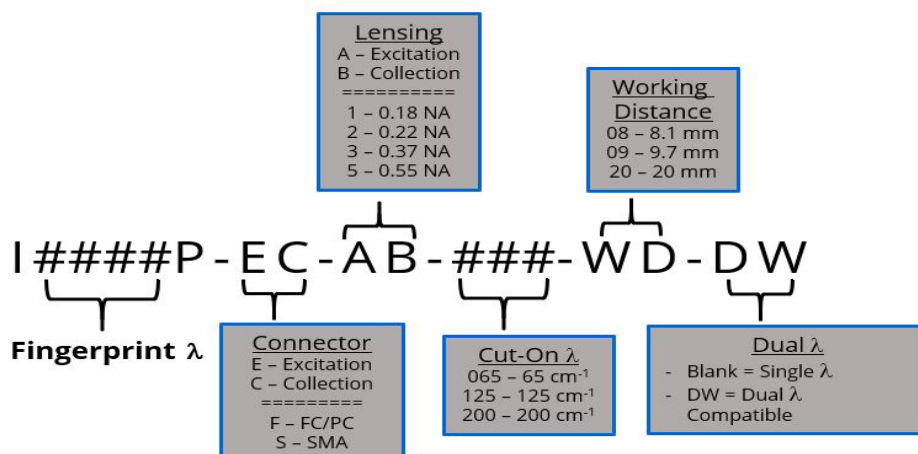

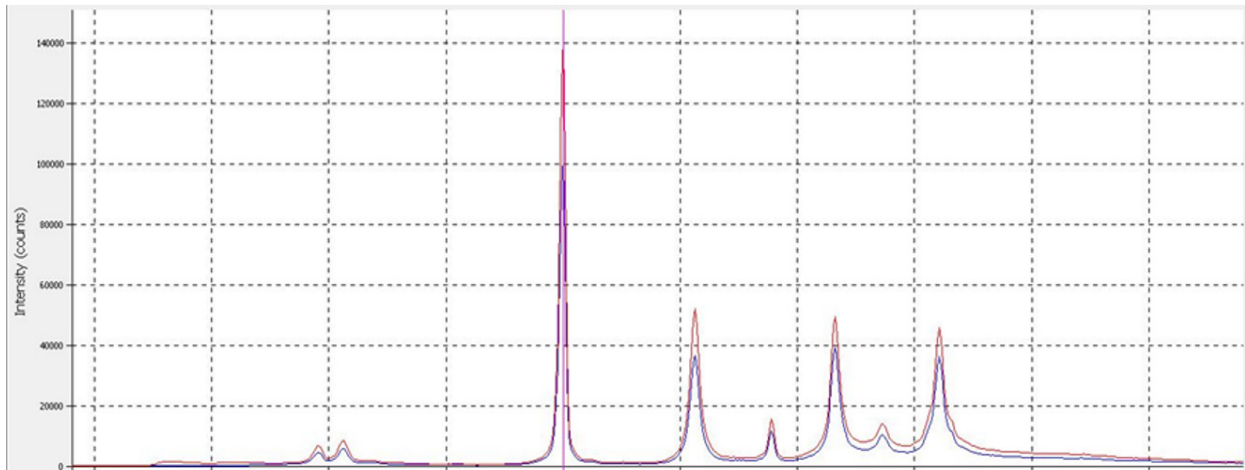

IPS Raman probe is shown in Red leading Raman Probe product shown in blue

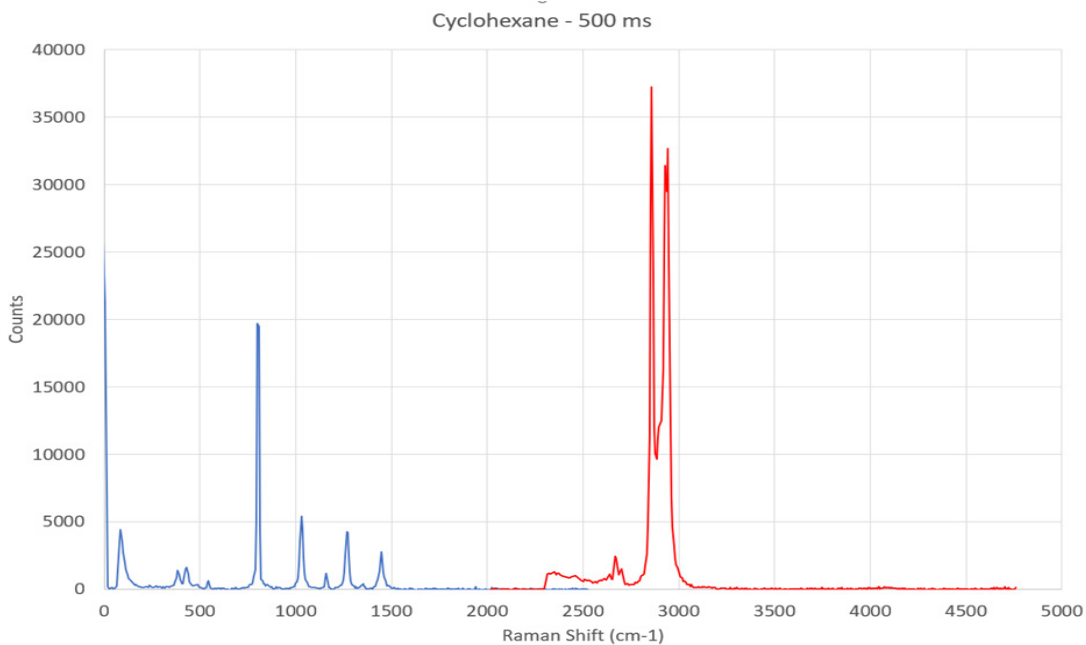

Raman concatenated spectrum (dual wavelength, single spectrometer) of cyclohexane

## Custom Capability

- Multiple excitation wavelengths offered.
- SMA / FC-PC / FC-APC collection and excitation fiber connectors.
- 8.1mm - 20 mm working distances available.
- Multiple cut-on wavelengths offered.
- Multiple excitation and collection numerical aperture collimation optics and fibers available.
- Single and Dual wavelength designs available.
- Immersion Probe Tips Available on Request.

# Mechanical Drawings

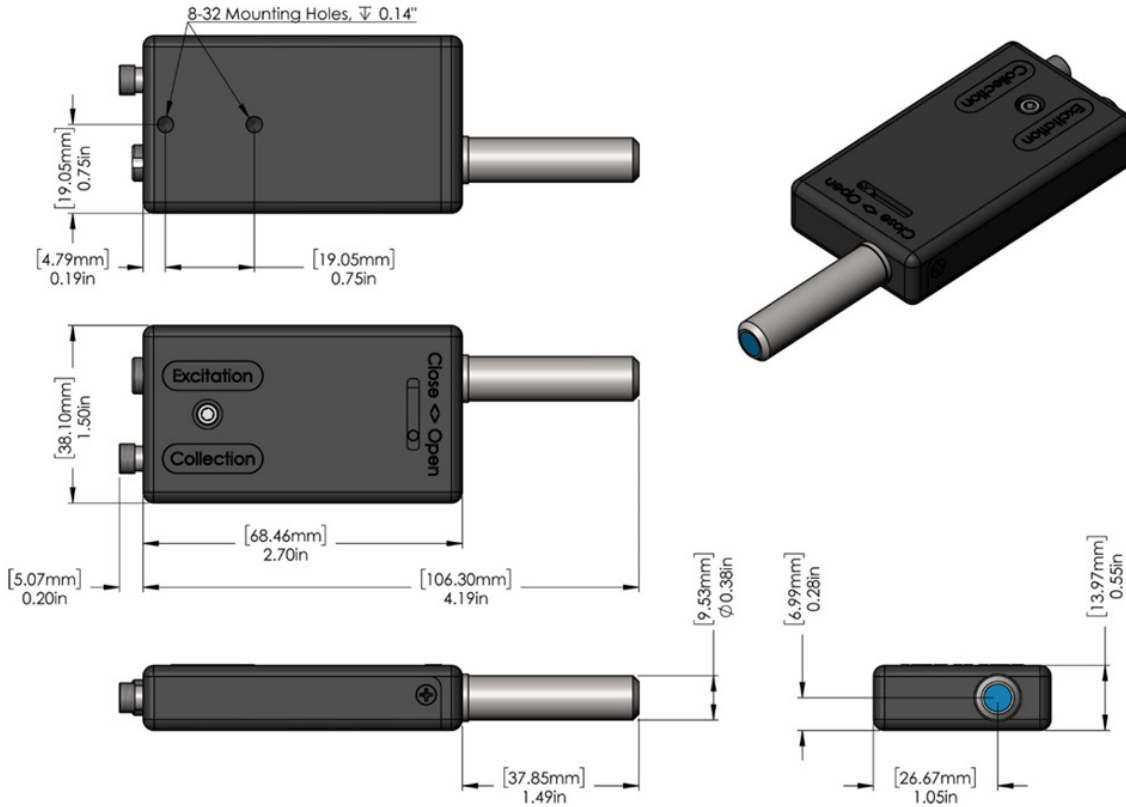

## Operational Notes

- \*\*NOTE\*\*** - Excitation and collection fibers are not included with High Throughput Raman Probe. Customers can order fibers directly from IPS or purchase independently

Innovative Photonic Solutions, Inc.  
313 Enterprise Drive  
Plainsboro, NJ 08536

Phone: (732) 230-1601

sales@ipslasers.com  
www.ipslasers.com

